

Steeline Square Gutter

SQUARE GUTTER

ST18



Colorbond® Zinalume®

Square Gutter is an appealing, modern profile that suits a multitude of building designs. The continuity of the gutter line profile can be maintained on barges with the square barge capping. The medium gauge metal has rollformed ribs on the front face, offering great resistance to denting and a stylish, buckle free appearance. Made from COLORBOND® or ZINCALUME® Steel that is strong and long lasting.

Ph. 1300 STEELINE

steeline.com.au



Service over and above

Steeline Square Gutter

SQUARE GUTTER

ST18

Installation

Fixing to timber fascia

Fix a bracket at the high end of fall first, then fix a bracket at the low end of the fall. Stringline a common datum on both brackets, and install the remaining brackets at the required spacing (not exceeding 1200mm) with common datum on the stringline.

The brackets are best attached to the fascia with the use of 20mm bugle head self drilling screws.

Attaching gutter to brackets

Hook the front of the gutter onto end of the long arm of the brackets, then slide the back of gutter under the long arm, until it is hard up to the back of the bracket. Push the gutter into the upright position, lifting the bottom of the gutter onto the platform provided by the bracket. When the gutter is in the correct position, turn down both tabs of the gutter brackets onto the back of the gutter to complete the attachment.

Spring Clip System

Fixing to metal fascia is made very easy by using the Steeline spring clip. The clip snaps over the metal fascia, and has six teeth at alternative heights. The fall of gutter to downpipe outlet is determined by the height of the gutter attached to these teeth. The face of gutter is then supported by the Steeline overstraps, which connect in front bead of the gutter and top bead of the fascia.

Support Recommendations

Gutter brackets spacing should not exceed 1200mm. Where metal fascia is used brackets must be placed within 150mm either side of the rafter brackets.

Stop Ends

Preformed stop ends provide a neat finish to straight runs of gutter, and require less labour and skill than site formed ends. However both methods require the use of rivets and a roofing type silicone sealant.

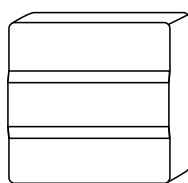

Stop End

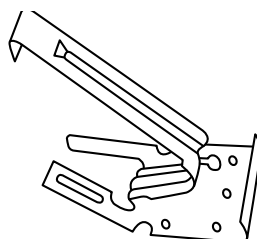

Internal Bracket

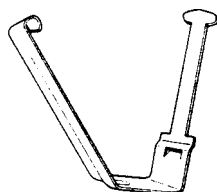

Overstrap

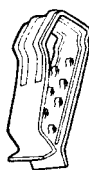

Spring Clip

External Corners

Cut as shown in illustration, fold, rivet and seal.

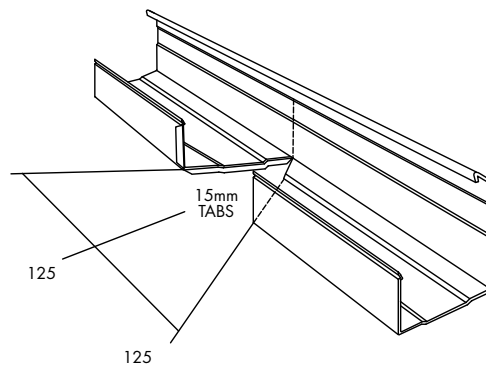

Internal Corners

Cut as shown in illustration, fold, rivet and seal.

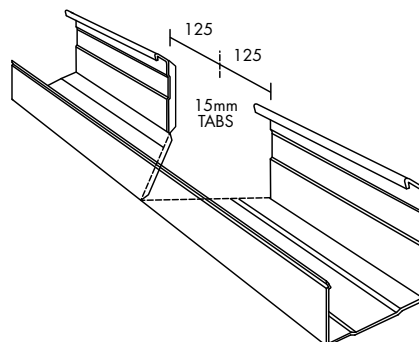

Gutter Joining

To produce a slip joint, notch gutter as shown in the illustration. Insert reduced end into normal end, rivet and seal.

